

REVISIONS	BY

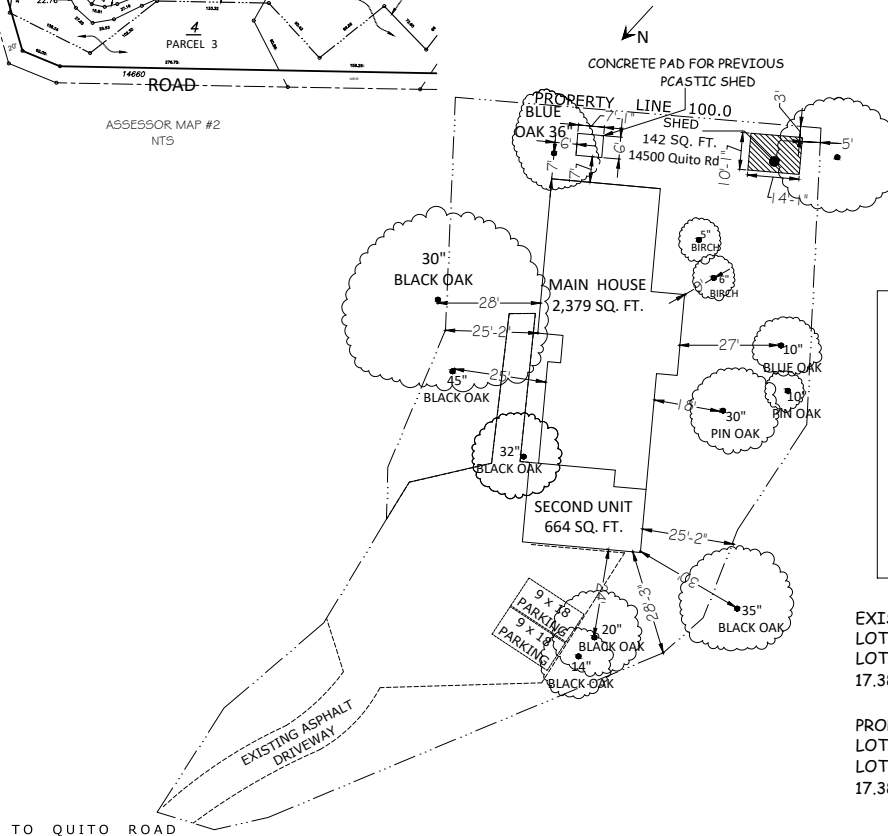
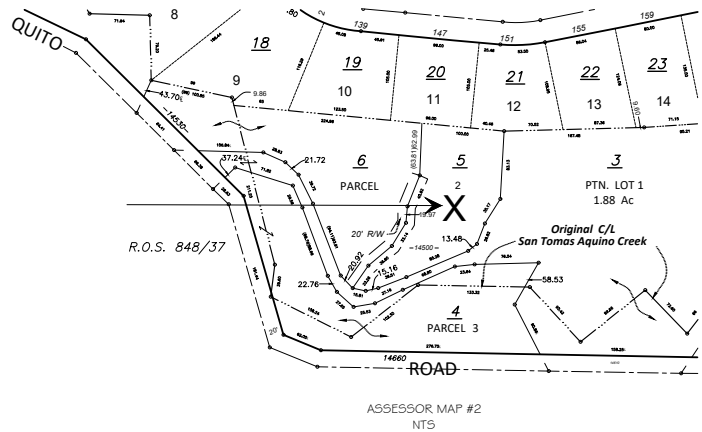

PROPOSED PLOT PLAN #1
Scale: 1/32" = 1'

BUILDING CRITERIA
 2016 CALIFORNIA RESIDENTIAL CODE
 2016 CALIFORNIA MECHANICAL CODE
 2016 CALIFORNIA PLUMBING CODE
 2016 CALIFORNIA ELECTRIC CODE
 2016 CALIFORNIA ENERGY CODE
 2016 CALGREEN CHECKLIST
 CITY OF LOS GATOS AND SANTA CLARA CONSTRUCTION ORDINANCE

INDEX
 PAGE 1: PROPOSED PLOT PLAN
 PAGE 2: PROPOSED ELEVATION & ELECTRICAL

EXISTING MAIN HOUSE:	2,379 SQ. FT.
ATTACHED DWELLING UNIT	664 SQ. FT.
TOTAL BOTH UNITS:	3043 SQ. FT.
SHED	142 SQ. FT.

SCOPE OF WORK: NEW SHED

- PROPERTY ZONING : R-1:10
- 142 SQ. FT. SHED
- 2 ELECTRICAL LIGHTS INSIDE NEW SHED
- 2 LIGHTS OUTSIDE NEW SHED
- 3 RECEPTACLES IN NEW SHED
- NO TREE REMOVAL & NO GRADING
- NUMBER OF STORIES : 1
- TYPE OF CONSTRUCTION : V-B

EXISTING LOT COVERAGE
 LOT SIZE: 17,511 SQ. FT. APPROX.
 LOT COVERAGE: 3,043 SQ. FT. OR
 17.38% OF TOTAL LOT.

EXISTING F. A. R.
 LOT SIZE: 17,511 SQ. FT. APPROX.
 FAR COVERAGE: 3,043 SQ. FT. OR
 17.38% OF TOTAL LOT.

PROPOSED LOT COVERAGE :
 LOT SIZE: 17,511 SQ. FT. APPROX.
 LOT COVERAGE: 3,185 SQ. FT. OR
 17.38% OF TOTAL LOT.

F. A. R.
 LOT SIZE: 17,511 SQ. FT. APPROX.
 LOT COVERAGE: 3,185 SQ. FT. OR
 17.38% OF TOTAL LOT.

FAR SQ.FT. MAXIMUM : 5,576 SQ.FT. & MAXIMUM
 BUILDING COVERAGE 40%

APN: 407-14-005

OWNER: ANI CHAUDHARI (PROPOSED BY OWNER)
 ADDRESS: 14500 QUITO ROAD AND 14500-A QUITO ROAD
 LOS GATOS, CA
 TEL: 408-238-7894 EMAIL: ANICHAUDHARI@GMAIL.COM

DRAWN
CHECKED
DATE 04/23/19
SCALE 1/32" = 1'
SHEET 1
OF SHEETS

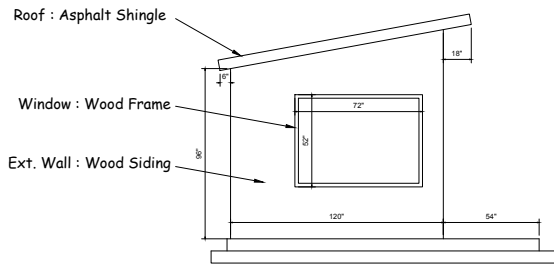

SIDE ELEVATION (NORTH)
Scale: 3/8" = 1'

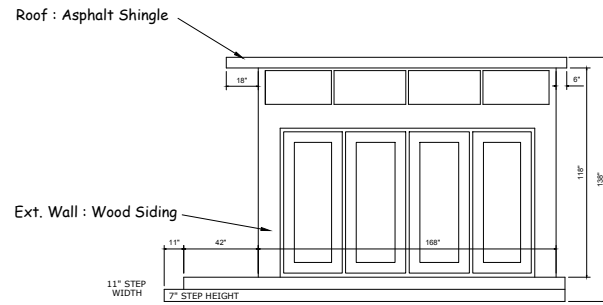

FRONT ELEVATION
Scale: 3/8" = 1'

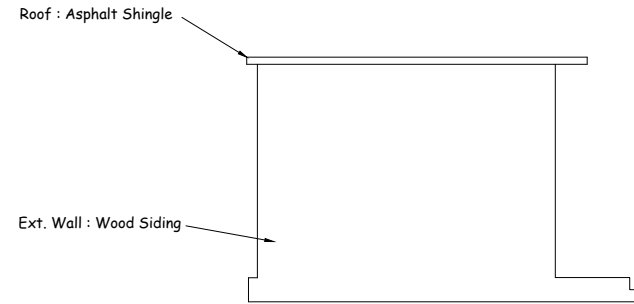

BACK ELEVATION
Scale: 3/8" = 1'

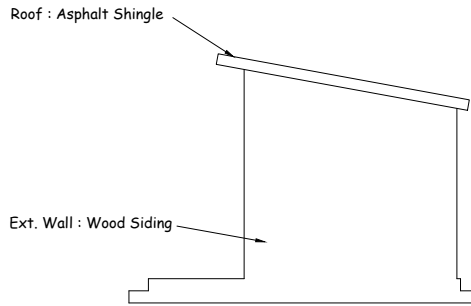

SIDE ELEVATION
Scale: 3/8" = 1'

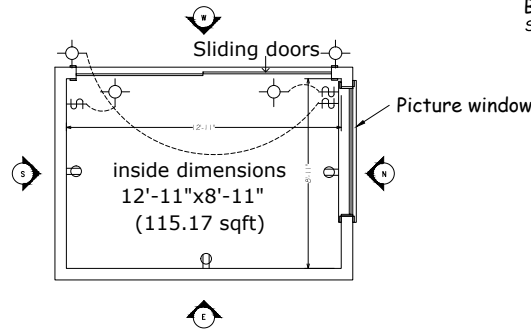

SHED PLAN: 14500 Quito Rd
Scale: 3/8" = 1'

- ELECTRICAL SYMBOLS
- LIGHTS
 - HEATING/AC REGISTERS
 - ELECTRICAL OUTLETS
 - WALL SWITCH
 - ELECTRICAL EXHAUST FAN
 - SMOKE DETECTOR
 - CARBON MONOXIDE DETECTOR
 - GFCI GROUND FAULT CIRCUIT INTERRUPTER
 - AFCI ARC FAULT CIRCUIT INTERRUPTER

SECONDARY UNIT WILL MATCH FROM , STYLE AND DETAILS OF MAIN HOUSE

NOTE 1: EXTERIOR LIGHTS FACING DOWNWARD & SHIELDED

NOTE 2: MATERIALS

EXTERIOR: WOOD SIDING

ROOF : ASPHALT SHINGLE

WINDOW : WOOD FRAME

COLOR : SHADES OF GRAY & WHITE
TRIMS TO MATCH MAIN HOUSE

REVISIONS	BY

PLAN & ELEVATIONS

APN: 407-14-005

OWNER: ANI CHAUDHURI (PROPOSED BY OWNER)
ADDRESS: 14500 QUITO ROAD AND 14506-A QUITO ROAD
LOS GATOS, CA
TEL: 408-228-7974 EMAIL: 2826CHBAVAVIA@GMAIL.COM

DRAWN

CHECKED

DATE

02/24/20

SCALE

3/8" = 1'

SHEET

2

OF SHEETS